

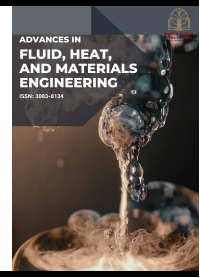

Advances in Fluid, Heat and Materials Engineering

Journal homepage:
<https://karyailham.com.my/index.php/afhme/index>
ISSN: 3083-8134



Development of an Automatic Ventilation System Using Internet of Things for Smart Kitchen Applications

Omar Abu Hassan¹, Lai Wee Kee¹, Nofrizalidris Darlis^{2,*}, Rasida Norjali¹, Hakimi Zohari¹, Md Nor Ramdon Baharom¹, Norrizal Mustafa³

¹ Department of Electrical Engineering Technology, Faculty of Engineering Technology, UTHM, 84600 Pagoh, Johor, Malaysia

² Department of Mechanical Engineering Technology, Faculty of Engineering Technology, UTHM, 84600 Pagoh, Johor, Malaysia

³ Faculty of Mechanical and Manufacturing Engineering, Universiti Tun Hussein Onn Malaysia (UTHM), 86400 Parit Raja, Batu Pahat, Johor, Malaysia

ARTICLE INFO

Article history:

Received 30 August 2024

Received in revised form 3 September 2024

Accepted 18 September 2024

Available online 30 September 2024

Keywords:

Internet of Things (IoT); automation ventilation system; MQ-2; Blynk

ABSTRACT

The advancement of the Internet of Things (IoT) has led to significant improvements in the safety and convenience of managing electrical appliances, with remote monitoring and control now accessible to most households. This connectivity allows for a seamless integration of technology into daily life, particularly in environments where safety is a critical concern. This study focuses on the development of an Automated Ventilation System aimed at reducing the risk of kitchen fires and gas leaks. The system uses the MQ-2 gas sensor module, which has been tested with four types of gases: lighter gas, burning paper smoke, steam from boiling water, and Buddha incense smoke, to ensure accurate detection. When smoke levels exceed predefined thresholds, a relay activates the exhaust fan. The system is managed by a NodeMCU equipped with an ESP8266 Wi-Fi module, which enables connection to the Blynk platform. This setup allows users to monitor the system and receive alert notifications on their smartphones, ensuring prompt response when connected to the internet. The implementation of this IoT-based system significantly enhances kitchen safety by providing automated and real-time responses to hazardous smoke levels.

1. Introduction

A study by the World Health Organization shows that 3.8 million individuals die early from indoor air pollution caused by cooking, especially due to pneumonia and ischemic heart disease, followed by chronic obstructive pulmonary disease (COPD). Smoke from the kitchen can invade the respiratory tract with air and cause mental problems. Over time, irritation of the respiratory tract causes rhinitis, skin problems, weakened immunity, and more severe cancer [1-5].

Thus, a good kitchen ventilation system, as one of the necessary kitchen appliances [6], is needed to remove cooking irritants in the air and can benefit from better adjusting the temperature in the kitchen area during cooking or not. The importance of the Internet of Things (IoT) is paramount for

* Corresponding author.

E-mail address: nofrizal@uthm.edu.my

<https://doi.org/10.37934/afhme.2.1.1122a>

the advancement of electrical appliances [7,8]. Smart electrical appliances allow humans to easily and quickly monitor and control devices at any time and from any location through Internet of Things (IoT) applications [9-11]. The IoT can improve our daily lives by automating every small task around us.

The increased smoke concentration during cooking in the kitchen can affect healthy human beings to a certain extent if people are not vigilant, especially women [6,12]. A good ventilation system is necessary in every kitchen to prevent excessive smoke from cooking. Hence, the IoT will play a crucial role in building a smart ventilation system that allows controlling and monitoring functions in a kitchen using the Internet. Likewise, it can be widely used in smart home automation systems. This study aims to investigate the IoT systems in an automatic ventilation system for smart kitchen applications, designs and constructs an automatic ventilation system for such applications using sensors and microcontrollers, and validates the developed system for its functionality.

In 2020, Ashraf *et al.*, [13] designed and constructed a home automation system that focuses on remote control of basic electrical appliances. The authors built the system using a smartphone app, Microsoft Azure cloud database with the fastest-growing Cloud Infrastructure Platform, a microprocessor Raspberry Pi, 5 V relay circuits, and electrical appliances. The main achievement of this system is that it allows more efficient use of electrical appliances by showing their current states and providing "notices" to the user if it is left on for more than two hours.

Another previous study was conducted in 2021 By Ahmad *et al.*, [14] from the University of Tun Hussein Onn Malaysia. Their system uses Micro:bit to drive the system effectively. It automatically switches on the fan and light and activates the PIR Sensor to detect any motion and turn it off when no motion is detected. In the future, the ideas of Micro:bit-based automation of electrical appliances can also be applied to other electrical items, thereby making human existence easier and better. For software development, they apply Bluetooth in smartphones to control the light and fan but need to download the apps of "micro:bit and MIT AI2 Companion at previous.

According to previous studies [10,15-17], every smart home automation system uses the Internet of Things (IoT) concept. The general concept of IoT is to apply the Internet to connect and monitor things remotely. When IoT applies to smart home automation via mobile apps, we will be able to control and monitor our home appliances efficiently and conveniently; safety will also be considered.

2. Methodology

This section will discuss in detail the implementation and development of the project through a series of project flows. The methodology details the research approach to provide accurate, valid data that meet the objectives.

2.1 System Operation Flowchart

The flowchart shown in Figure 1 was created to explain the processes in detail and demonstrate how the system runs. First, power is connected through a USB cable to the NodeMCU board, and a 12-V adapter serves as the external power source to support the DC fan. The NodeMCU with the ESP8266 Wi-Fi module interface interacts with Blynk via Wi-Fi conditions. A hotspot on the Android device must be turned ON in advance to allow the start of the ESP8266 Wi-Fi module to successfully connect to the Blynk application. After connection, Blynk is displayed in the connected mode. However, if the system still cannot connect to Wi-Fi, press the RST button or reconnect the USB cable from NodeMCU.

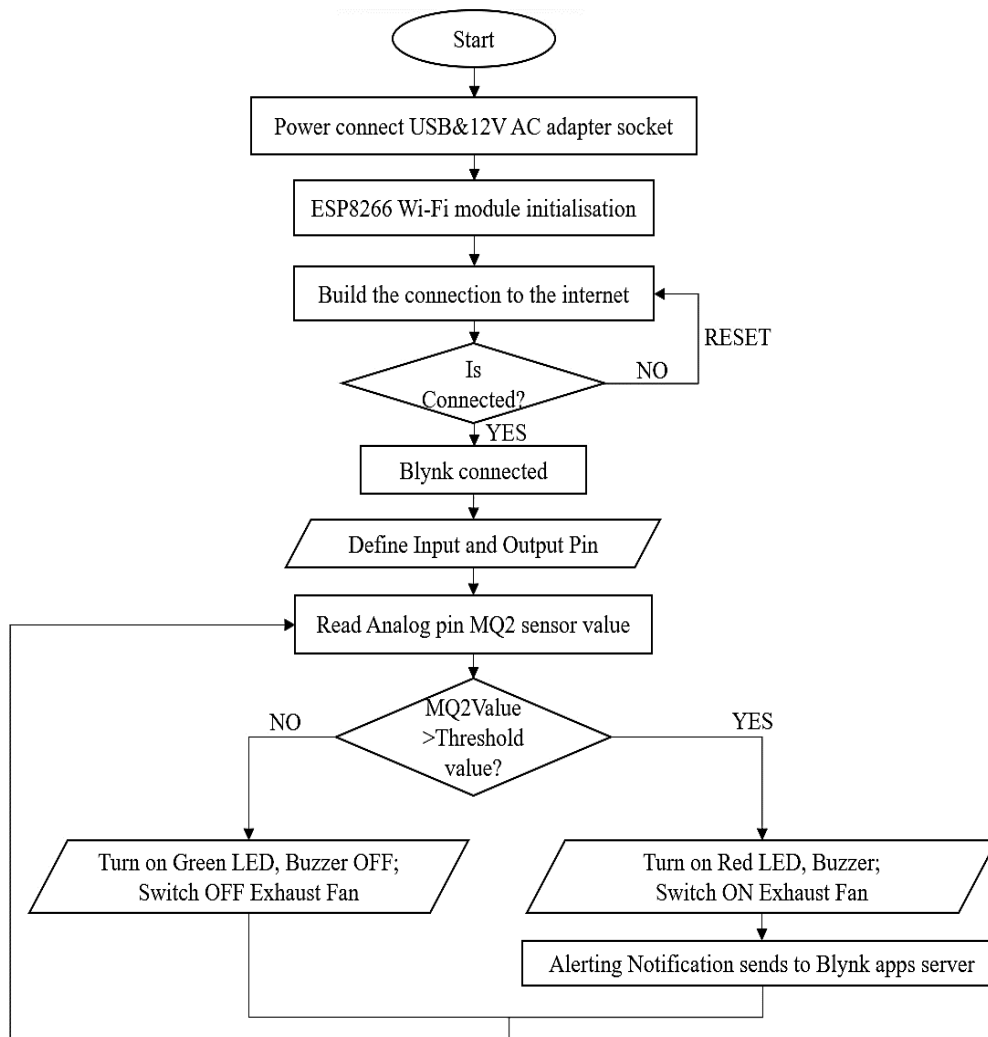

Fig. 1. Gas detection system flowchart

The MQ-2 gas sensor module transmits an input signal to a NodeMCU analog pin (A0) that reads and displays the values in the Blynk application and Serial Monitor. Under the experimental conditions, the threshold of the MQ-2 sensor was set, and the sensor began to detect gas particles in the surrounding area. The green LED turning on indicates good condition. If smoke is detected by the sensor and its value is higher than the set threshold, the red LED and buzzer will turn ON, and the Blynk LCD screen will display "SMOKE LEAKAGE!!! FAN ON". The exhaust fan automatically switches on to exhaust the smoke. In addition, alert notifications are sent via the Blynk apps server every 1 second. If no smoke is detected, the system continues to read the sensor's analog-pin values until the power is off.

2.2 Project Block Diagram

Figure 2 shows a general block diagram of the project. The input part only includes one MQ-2 sensor, which provides analog values, while the output part consists of two LEDs, a Buzzer, a 5 V Single Channel Relay module, and a DC fan. The NodeMCU is responsible for performing and analyzing all data from sensors (Input) and transmitting the relevant signals to the actuators (Output). In addition, it can operate based on the coding uploaded to it. The DC exhaust fan is supplied by an external 12 V power supply and is triggered by a 5 V relay module when a condition occurs.

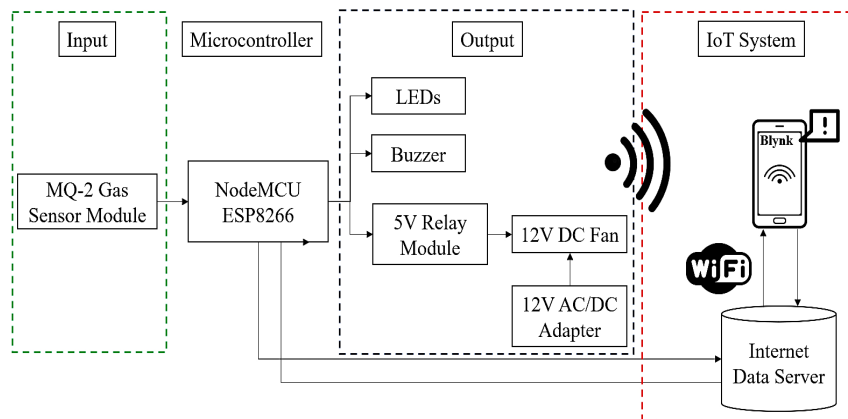

Fig. 2. Block diagram of the gas detection system

5 V sources power the MQ-2 gas sensors and send analog values to NodeMCU during gas detection. The NodeMCU then receives and processes the data to the output devices. The output devices are the 1 buzzer, 2 LEDs, and a DC exhaust fan. The LEDs and buzzer are ON when the sensors detect something. The gas values will also be displayed on Blynk apps and with a pop-up notification when the values are greater than the set threshold. Finally, the ESP8266 Wi-Fi module sends data to Blynk as the IoT platform of the proposed system. Blynk apps are installed on the mobile device.

2.3 Schematic Diagram of the System

Figure 3 shows a schematic of the smoke detection system. The NodeMCU comprises both analog and digital pins, which allow connection with other components in the circuit. The NodeMCU only consists of one analog pin (A0), the MQ-2 sensor is linked to it, sends an analog signal to the NodeMCU, and displays the Blynk apps via the ESP8266 Wi-Fi connection.

The positive polarities of the green and red LEDs are connected to D1 and D2, and the negative polarities are connected to the ground. The buzzer is connected to D3, and all the ground must connect at the same phase via a 220Ω current limiting resistor. The output of the NodeMCU is connected to the input of the 5 V relay via D8, which allows the NodeMCU to operate the relay. Two DC power supply units supplied electricity to the circuit. One was +12 V DC to power the DC fan, while the other was +5 V DC to power the sensor, 5 V relay, and other output devices via the USB cable that connects to the NodeMCU.

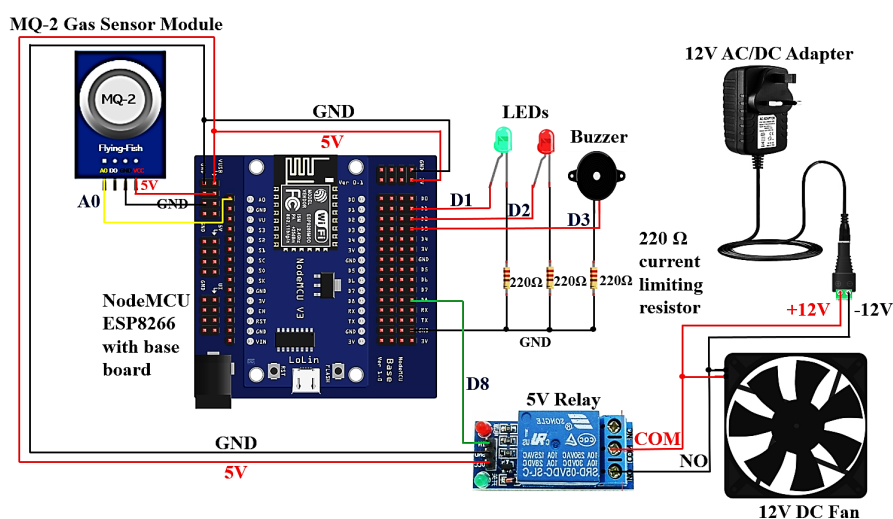

Fig. 3. Schematic of the gas detection system

2.4 Estimation of Gas Concentration Detected by MQ-2 Sensor

The formula used to calculate the gas concentration in parts per million (ppm) and percentages (%) is shown in Eqs. (1) and Eq. (2) below.

$$\text{Gas concentration(ppm)} = \frac{\text{Value read from the analog sensor}}{\text{Maximum analog input}} \times 10000 \quad (1)$$

$$\text{Percentage Gas concentrations(\%)} = \text{Gas concentration(ppm)} \times 100 \quad (2)$$

2.5 Characterization of the MQ-2 sensor

The MQ-2 gas sensor module is connected to the NodeMCU, as shown in Figure 4. The potentiometer behind the module must first be calibrated to adjust the sensor's Digital Output sensitivity. For testing using the analog output, the module determines whether the gas concentration is above or below the setting threshold.

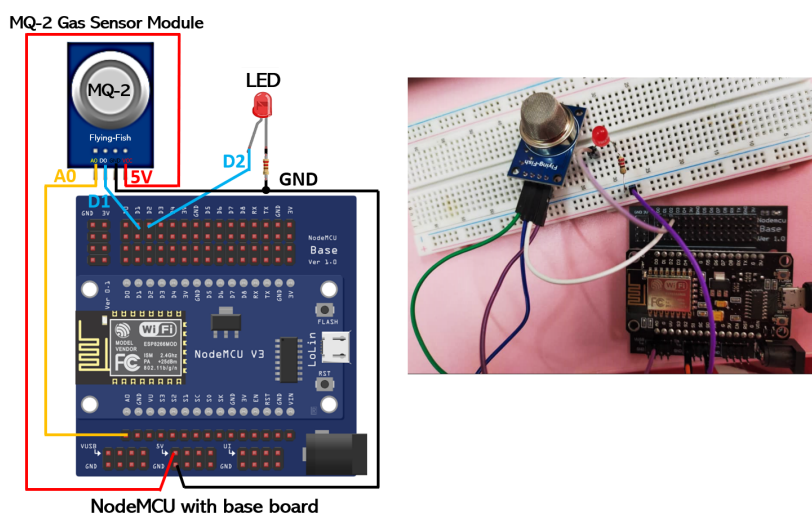

Fig. 4. MQ-2 gas sensor connection for character testing

Figure 5 shows the status when no gas was detected; the status LED behind the MQ-2 module was OFF; the Gas Class (D1) was HIGH; and the red LED was OFF. When the sensor detected butane from a lighter, the analog output of the sensor increased rapidly. The ON LED status behind the MQ-2 module indicates that the gas concentration exceeded the set threshold (>300). In addition, the red LED was turned ON, and the Gas Class (D1) decreased, as shown in Figure 6.

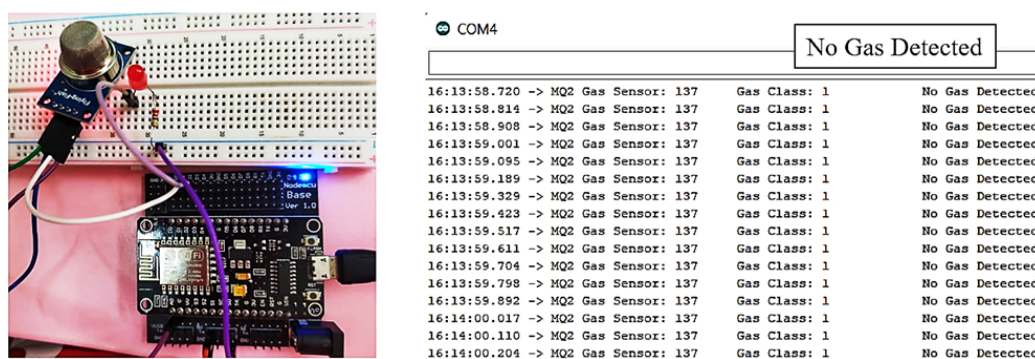

Fig. 5. Serial monitoring of the MQ-2 gas sensor when no gas was detected

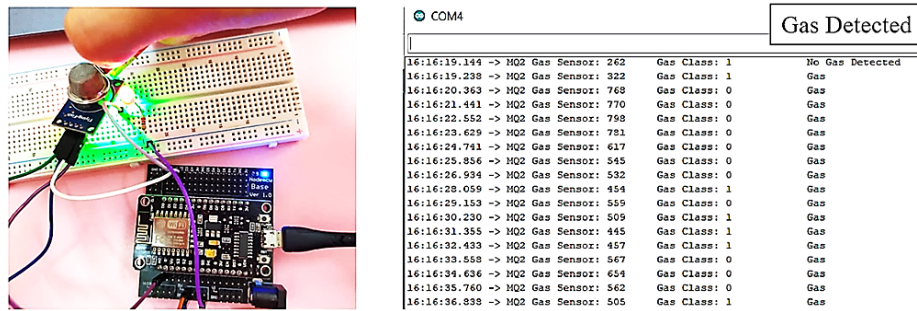

Fig. 6. Serial monitoring of the MQ-2 gas sensor when gas is detected

2.6 Ventilation Fan Functionality Using Relay

Figure 7 shows the relay connection to the DC Fan (represent as a ventilation fan) as a load that was linked to the Normally Open (NO) relay switch. The 12 V AC/DC adapter was the external power supply for supplying the DC fan. The relay is a convenient switch to turn ON and OFF the DC fan; it controlled by the widget buttons in the Blynk application.

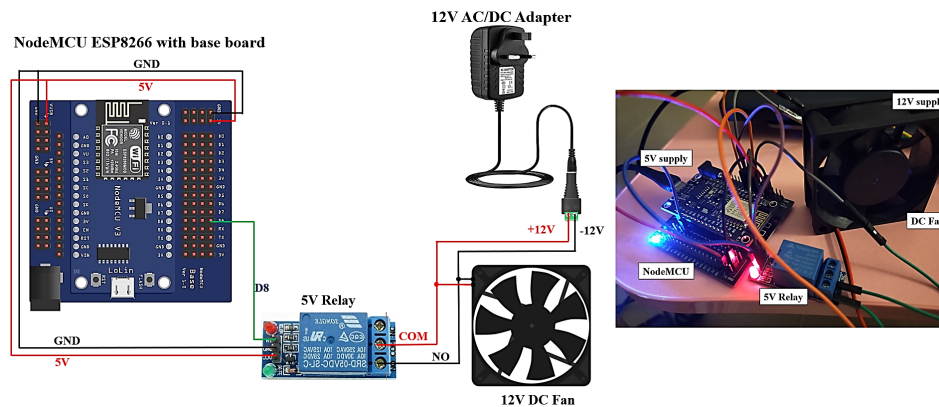

Fig. 7. Ventilation fan connection using 5V relay

Figure 8 DC Fan remains OFF when the widget button is released and ON when the widget button is pressed on the Blynk app. The status relay LED is also shown.

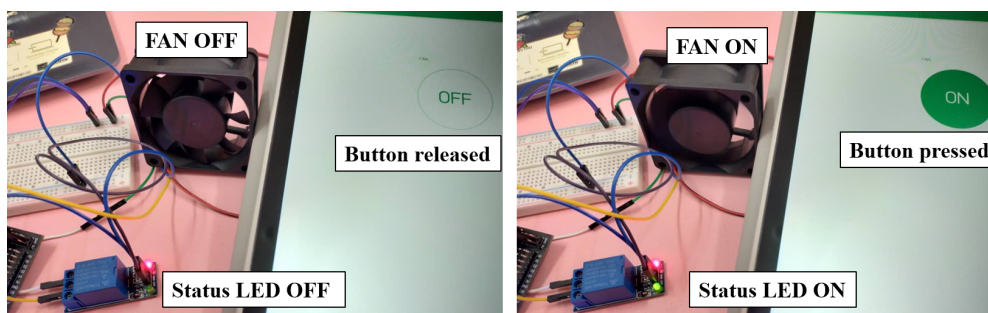

Fig. 8. Operation of the ventilation fan (ON/OFF condition) controlled by a 5-V relay

2.7 Full System Prototype Setup

All electronic components were correctly installed to ensure that the system operated smoothly. The breadboard separates the two DC sources: a 5 V source from the USB cable and a 12 V source

from the 12 V adapter. All connections should be performed under non-powered conditions to prevent short circuits from occurring and to destroy any component, especially the NodeMCU board.

The development starts from Figure 9, where the NodeMCU is connected to the analog input of the MQ-2 gas sensor module, and the digital output is a buzzer and 2 LEDs. Next, we proceed to the connection of the 5V relay and DC Fan. The external power supply for the DC fan was a 12 V AC/DC adapter. Finally, the entire system was connected, as illustrated in Figure 10.

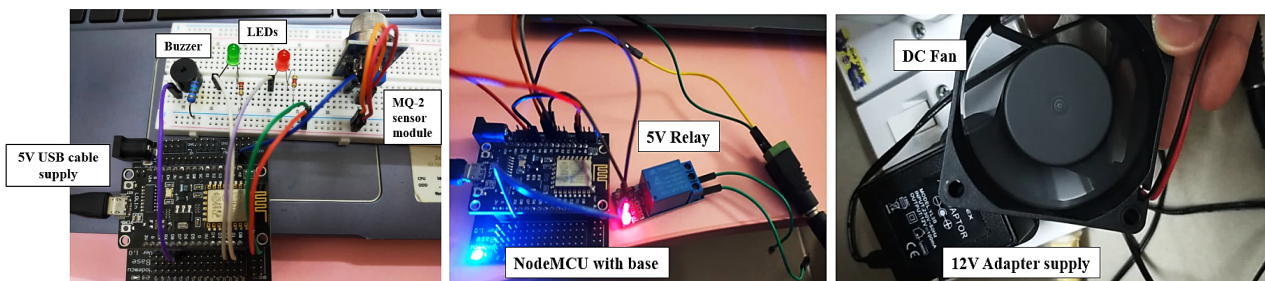

Fig. 9. Early system development

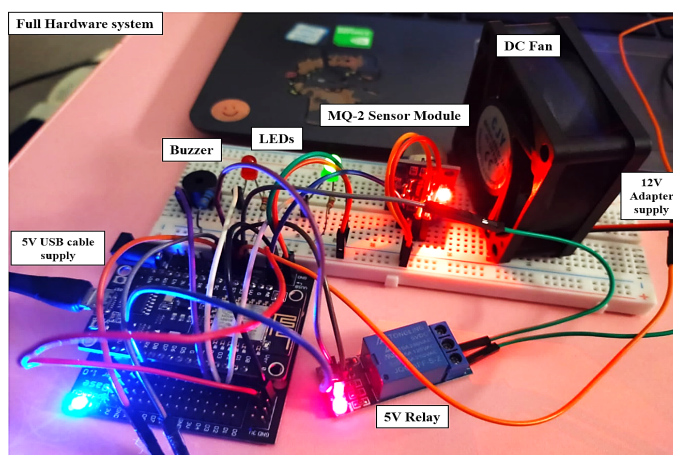

Fig. 10. Final full hardware setup of gas detection system

Some issues were identified while completing the hardware and software required for this project. The first issue came from the MQ-2 gas sensor module's functionality. Some conditions, such as water and high voltage, must be restricted to prolong sensor sensitivity. Figure 11 shows that the heater on the right side of the sensor was polluted. When the sensor is tested, it will provide the highest gas value until 1024 but will not generate smoke. Thus, it cannot provide stable value for any system during gas detection. The problem was resolved by replacing the MQ-2 gas sensor module with a new module.

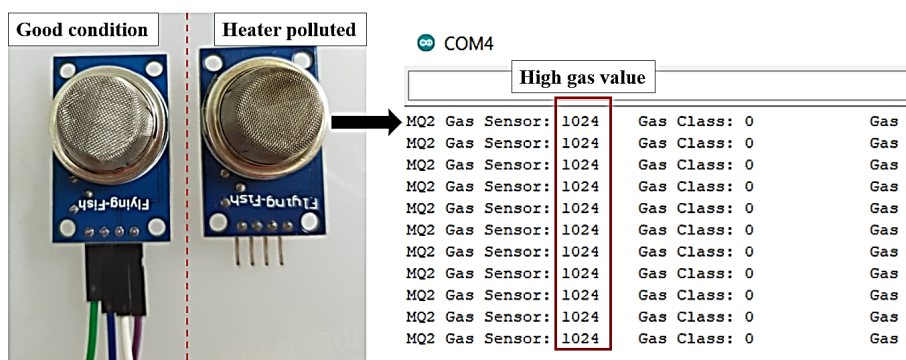

Fig. 11. Heater-polluted MQ-2 sensor and serial monitoring

These challenges involved the Wi-Fi connection of the ESP8266 microcontroller, which receives, processes, and transmits data from the system to Blynk applications. When power was connected to the circuit, the board easily lost its Wi-Fi connection; thus, the wires that connected the relay and NodeMCU needed to be plugged out. It can be connected back until the board successfully links to the Wi-Fi status. The Wi-Fi connection status can be checked in the serial monitor of Arduino IDE or in the hotspot setting of the smartphone.

3. Results

3.1 Initial Testing of Various Types of Gas Detection

When the MQ-2 sensor detected no gas, the system was considered in good condition. The relay did not trigger the exhaust fan, the green LED was turned on, and the buzzer was not activated. ESP8266 transfers the gas value to the Blynk apps; no alerting notification is received, as shown in Figure 12.

When the MQ-2 detected the presence of butane gas from a lighter (Figure 13), the relay coil triggered the exhaust fan to move automatically, the red LED was turned ON, and the buzzer was activated to produce a loud beep sound. The data will be sent to the Blynk apps on the user's device with a pop-up notification every second until the detected gas is exhausted.

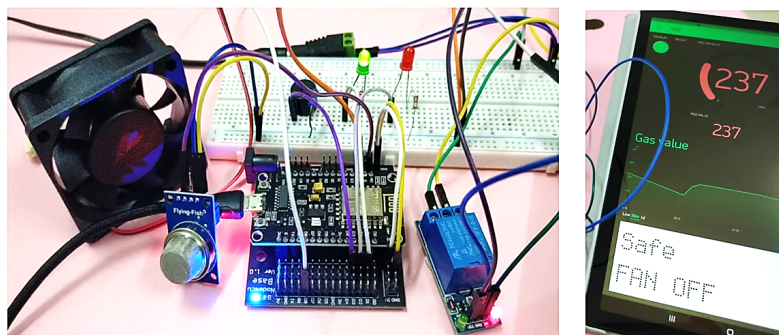

Fig. 12. No gas detected condition circuit setup and Blynk display



Fig. 13. Gas-detected condition circuit setup, Blynk display, and pop-up alert notification

3.2 Gas Detection Testing Result and Analysis

Figure 14 shows gas value charts displayed in the Blynk apps according to the various gases detected by the MQ-2 sensor. Table 1 shows that the MQ-2 gas sensor is more sensitive to butane gas produced from lighter than to burning paper, cooking, and buddha smoke. The purpose of

comparing the gas value detection range was to set threshold values in the system that would trigger when the exhaust fan turned on to exhaust function under dangerous conditions.

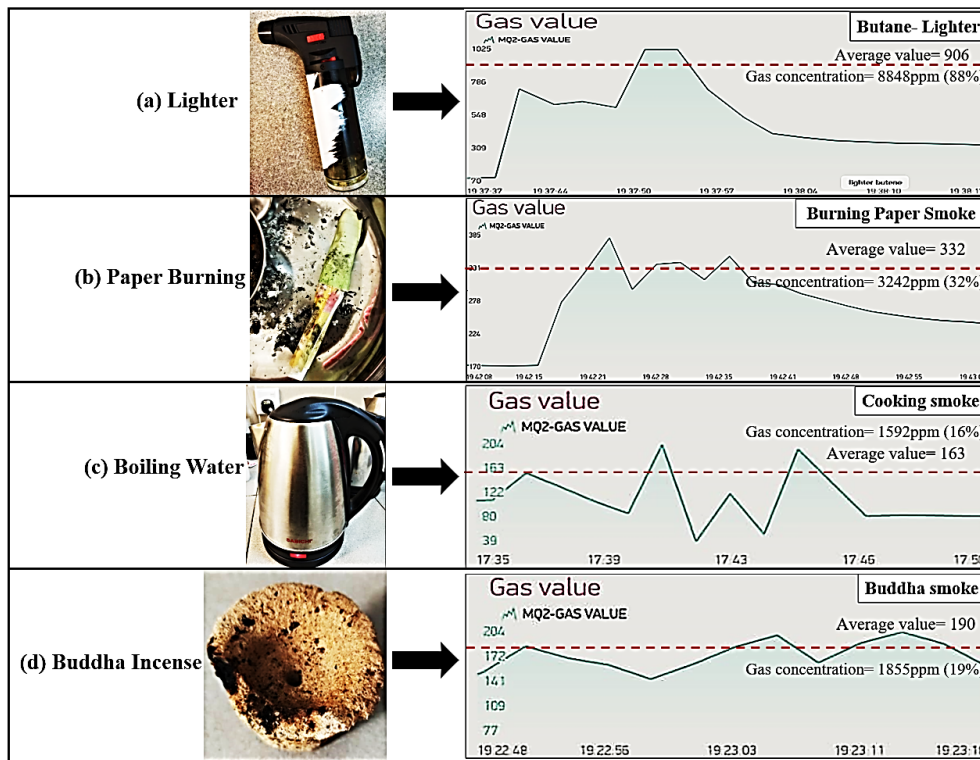

Fig. 14. Gas detection reading characteristic of 4 different types of gas

The result given in Table 1 only shows the analog values of the MQ-2 gas sensor module without a specific chemical substance of gases being detected; thus, for the safety gas level, we refer to Tables 2 and 3.

Table 1
 Comparison of different gases under different conditions

Types of gas detected	MQ-2 gas detection range			Gas concentration (from average)		Conditions
	Min	Max	Average	ppm	%	
Butane lighter	786	1025	906	8848	88	Dangerous
Burning paper smoke	278	385	332	3242	32	Alert
Cooking smoke	122	204	163	1592	16	Safe
Buddha smoke	172	204	190	1855	19	Safe

Table 2
 Carbon monoxide (CO) safety index levels and effect

CO Concentration (ppm)	Effects on body
<60	Maximum safety level.
>60	Headache, breathless.
>150	Nausea, dizziness, and decreased dexterity.
>1000	Fatal.

Table 3
 Carbon dioxide (CO₂) safety index levels and effects

CO ₂ Concentration (ppm)	Effects on body
<1000	Maximum safety level, no health effect, acceptable of indoor air quality.
1000-2500	Fatigue, breathless, uncomfortable stuffy feeling in the air.
>2500	Fatigue, sleepiness, and headache.
>100000	Minutes-long unconsciousness, coma, and mortality risk.

In addition, the MQ-2 gas sensor detection results are better when the sensor module distance is closer to the leaking site. Figure 15 shows the four different types of gas detection based on the sensor placement distance. The MQ-2 gas sensor module was placed upward for easy contact with the surrounding gas; the sensor placement distances were written on the cardboard as 30, 60, and 90cm. This result was obtained in open air; thus, it was challenging to collect gas centrally. Sometimes, wind can affect sensor detection.

From the analysis comparison in Table 4, the farther the distance, the lower was the measured gas value and gas concentration detected by the MQ-2 sensor. As a result, the gas concentration readings decreased as the distance increased to 90 cm. Therefore, the distance between the MQ-2 sensor and stove must be at least 30–60 cm to allow the sensor to detect gas values more sensitively. Otherwise, MQ-2 would take more time to detect gas, and the sensor threshold must also be very low for smoke detection. Nevertheless, the final results include limitations that cannot be compared with other sensors due to time and cost limitations.



Fig. 15. Gas detection at different sensor placement distances

Table 4
Gas concentration (ppm) at different sensor distances

Types of gas detected	MQ-2 gas concentration (ppm) in different sensor distances		
	30cm	60cm	90cm
Butane lighter	6338	3223	1855
Burning paper smoke	1406	1308	1230
Cooking smoke	1406	1270	1113
Buddha smoke	1914	1826	1729

4. Conclusions

In conclusion, the project will develop a sensor-based Automatic Ventilation System for smart kitchen appliances using IoT. The sensor involved is the MQ-2 gas sensor module used to detect the smoke in the kitchen, and the relay triggers an exhaust fan to expel the smoke when it reaches a threshold value. With the involvement of IoTs, users can receive messages through smart applications. In addition, IoT technology can improve human lives by automating every small task. The primary goal of this project is to investigate IoT systems in an automatic ventilation system for smart kitchen applications. This goal was achieved because the NodeMCU with the ESP8266 Wi-Fi module can cooperate with the Blynk application to monitor the gas value of the MQ-2 sensor. The second goal was to design and construct an automatic ventilation system for smart kitchen applications. The final objective was to verify the functionality of the developed system on the designed prototype. However, it can only be monitored online when the user is connected to the internet.

Future improvements for this project include using buttons to force switch off the system's buzzer after confirming receipt of the alerting notification or not the notice will alert for a long time until the gas value is lower than the set threshold. Moreover, the best result is that the sensor should be compared with other sensors to improve its validity and accuracy. The MQ-2 gas sensor module is suitable only for measuring trends in gas concentrations and not for precise gas concentration measurements. For a more precise gas concentration, an expensive calibration kit is required, such as a gas tank, flow meter, regulator, etc. It also requires some knowledge or skills to be applied to obtain more accurate readings.

Acknowledgement

The authors would like to thank the Faculty of Engineering Technology, Universiti Tun Hussein Onn Malaysia for its support.

References

- [1] Farmer, Stephen A., Timothy D. Nelin, Michael J. Falvo, and Loren E. Wold. "Ambient and household air pollution: complex triggers of disease." *American Journal of Physiology-Heart and Circulatory Physiology* 307, no. 4 (2014): H467-H476. <https://doi.org/10.1152/ajpheart.00235.2014>
- [2] Goldemberg, Jose, Javier Martinez-Gomez, Ambuj Sagar, and Kirk R. Smith. "Household air pollution, health, and climate change: cleaning the air." *Environmental Research Letters* 13, no. 3 (2018): 030201. <https://doi.org/10.1088/1748-9326/aaa49d>
- [3] Apte, Komalkirti, and Sundeep Salvi. "Household air pollution and its effects on health." *F1000Research* 5 (2016): 1-13. <https://doi.org/10.12688/f1000research.7552.1>
- [4] Ahmed, Fahad, Sahadat Hossain, Shakhaoat Hossain, Abu Naieum Muhammad Fakhrudin, Abu Tareq Mohammad Abdullah, Muhammed Alamgir Zaman Chowdhury, and Siew Hua Gan. "Impact of household air pollution on human health: source identification and systematic management approach." *SN Applied Sciences* 1 (2019): 1-19. <https://doi.org/10.1007/s42452-019-0405-8>

- [5] Balmes, John R. "Household air pollution from domestic combustion of solid fuels and health." *Journal of Allergy and Clinical Immunology* 143, no. 6 (2019): 1979-1987. <https://doi.org/10.1016/j.jaci.2019.04.016>
- [6] Svendsen, Kristin, Hanne Naper Jensen, Ingvill Sivertsen, and Ann Kristin Sjaastad. "Exposure to cooking fumes in restaurant kitchens in Norway." *Annals of Occupational Hygiene* 46, no. 4 (2002): 395-400. <https://doi.org/10.1093/annhyg/mef045>
- [7] Fisher, Don, Rich Swierczyna, and Angelo Karas. "Commercial kitchen ventilation exhaust hoods." *American Society of Heating Refrigerating & Air-Conditioning Engineers (ASHRAE) Journal* 57, no. 11 (2015).
- [8] Dhane, Sumit S., and Suhas D. Jagtap. "Design of ventilation system for commercial kitchen." *International Research Journal of Engineering and Technology* 8, no. 7 (2021): 3182-3188.
- [9] Wang, Liang. "Research on IOT control module for smart kitchen based on AIOT technology." *Academic Journal of Science and Technology* 4, no. 2 (2022): 116-120. <https://doi.org/10.54097/ajst.v4i2.4119>
- [10] Bharti, Bhawana, Mahim Kumar, and Usha Chauhan. "Smart Kitchen using IOT." In *2023 International Conference on Artificial Intelligence and Smart Communication (AISC)*, pp. 796-799. IEEE, 2023. <https://doi.org/10.1109/AISC56616.2023.10084932>
- [11] Bharti, Bhawana, Indu Bharadwaj, and Ajay Bhardwaj. "Smart kitchen using IoT." *Global Journal of Innovation and Emerging Technology* 1, no. 2 (2022): 27-31. <https://doi.org/10.58260/j.iet.2202.0110>
- [12] Neghab, Masoud, Mahdiah Delikhoon, Abbas Norouzian Baghani, and Jafar Hassanzadeh. "Exposure to cooking fumes and acute reversible decrement in lung functional capacity." *The International Journal of Occupational and Environmental Medicine* 8, no. 4 (2017): 207. <https://doi.org/10.15171/ijjem.2017.1100>
- [13] Ashraf, Imran, Muhammad Umer, Rizwan Majeed, Arif Mehmood, Waqar Aslam, Muhammad Naveed Yasir, and Gyu Sang Choi. "Home automation using general purpose household electric appliances with raspberry pi and commercial smartphone." *Plos one* 15, no. 9 (2020): e0238480.
- [14] Ahmad, Muhammad Shukri, K. Puspanathan, T. Revi, and H. H. Tan. "Automated appliances using microbit." *Multidisciplinary Applied Research and Innovation* 2, no. 2 (2021): 94-100. <https://doi.org/10.1371/journal.pone.0238480>
- [15] Jabbar, Waheb A., Mohammed Hayyan Alsibai, Nur Syaira S. Amran, and Samiah K. Mahayadin. "Design and implementation of IoT-based automation system for smart home." In *2018 International symposium on networks, computers and communications (ISNCC)*, p. 1-6. IEEE, 2018. <https://doi.org/10.1109/ISNCC.2018.8531006>
- [16] Madakam, Somayya, Ramya Ramaswamy, and Siddharth Tripathi. "Internet of Things (IoT): A literature review." *Journal of Computer and Communications* 3, no. 5 (2015): 164-173. <http://dx.doi.org/10.4236/jcc.2015.35021>
- [17] Lueth, Knud Lasse. "IoT basics: Getting started with the Internet of Things." *White paper* (2015): 1-9.