



## Journal of Advanced Research in Computing and Applications

Journal homepage:  
<https://karyailham.com.my/index.php/arca>  
2462-1927



# Enhancing Underwater Colour Restoration using a Detectron-Autoencoder Hybrid Model

Mohamed Amgad<sup>1,\*</sup>, Essam El Fakharany<sup>1</sup>, Yasser Youssef<sup>2</sup>

<sup>1</sup> Department of Computer science, Arab Academy for Science, Technology and Maritime Support, Cairo, Egypt

<sup>2</sup> School of Library and Information Studies, the university of OKLAHOMA, Oklahoma, United States

### ARTICLE INFO

#### Article history:

Received 27 November 2026

Received in revised form 20 February 2026

Accepted 15 April 2026

Available online 16 June 2026

#### Keywords:

Underwater image colorization; deep learning; marine operations; image enhancement; color correction

### ABSTRACT

Image colorization in underwater environment has become a useful process for submarine operations. Colorized images can enhance the detection of specific targets or anomalies underwater, recently, most researchers of oceanology use high quality underwater images to make detailed analysis of submarine resources. This paper presents deep learning method for underwater images colorization. Studies show that training the deep learning models on a large dataset of underwater images and corresponding ground truth colour images improves objects definition and colorization in the image; hence, our model learns to segment objects from the underwater image, increase the intensity of degraded colours, merge the segmented object with the original image and to another image has different objects in the same context. This paper illustrates image processing techniques such as colour correction and restoration, for imaging challenges and extensive experiments that illustrate the high performance of the proposed model compared to existing state-of-arts, recovering true colours and enhancing overall image quality. The proposed model achieved good results in image colorization with accuracy of 92% that indicates model performance in classifying the targeted object.

## 1. Introduction

Underwater imagery addresses unique challenges for image processing. Poor visibility, complex backgrounds and fluctuating lighting conditions are considered as main challenges that stand against clear imaging. In underwater environments, light waves passing through water small particles leading to phenomena like scintillations and diffraction [1]. Dissolved salt in deep water constructs new elements that lead to colour degradation. When dissolved salt interacts with other factors, it causes many challenges in underwater imagery such as optical aberrations and image degradation [2]. The vertical distribution of light in the ocean, mediated by seawater characteristics, leads to the signal degradation [3].

\* Corresponding author.

E-mail address: [Mohamed.Abdo@student.aast.edu](mailto:Mohamed.Abdo@student.aast.edu)

<https://doi.org/10.37934/arca.43.1.120132>

It also causes photochemical reactions and photo oxidation [4]. Moreover, particles and bubbles in the water medium lead to significant signal attenuation, light refraction, absorption, and scattering [5]. Enhancing the quality of underwater images is necessary for such applications as underwater target recognition, monitoring marine life, and diagnosing faults in marine systems. Existing methods are often not able to effectively deal with the challenges presented by underwater images. In this work, a new approach has been developed, it is an integration of Detectron technology with an Autoencoder model, which promises to provide a good solution for underwater image enhancement.

Proposed model combines the strengths of both techniques to improve image quality, enhance details, and extract meaningful features from underwater scenes as seen in figure 1. This paper explores the development and evaluation of a Detectron-Autoencoder hybrid model for underwater image enhancement, showing its capabilities to enhance image processing in challenging marine operations.



**Fig. 1.** Result of our proposed approach

The growing interest in submerged monitoring and the utilization of maritime assets has inspired the researchers to pay more attention in underwater imagery. Underwater environments present unique challenges for example turbulence, diffusion, absorption, scattering of water, various noises, low contrast, uniform illumination, monotonous colour, and complex underwater backgrounds. Scattering and noise usually affects most of underwater photography due to the poor light in water and activities at the deep sea [6].

Researchers' interest in deep learning for market has developed the stock market rapidly and effectively. Stock market prediction models could get their good insights from developing deep learning models such as LSTM, ANN and ARIMA in forecasting market data like Bursa Malaysia KLCI [7]. Deep learning in medical field made good work to detect complex vessel structures. Using K-means clustering with Euclidean, Manhattan, Chebychev, and Mahalanobis distance metrics for retinal blood vessel segmentation has helped in finding the best performance in accuracy, precision, recall, and similarity metrics [8].

Internet of Things and Artificial Intelligence revolutionize aquaculture by enhancing productivity, sustainability, and resilience through real-time monitoring, disease detection, and resource optimization, contributing to global food security. They also have many crucial applications in predicting the robust and best design of floating structures and offshore platforms [9].

The challenges mentioned regarding underwater image processing include scattering, noise, colour distortion, the characteristics of light transport in water cause scattering, which degrades the quality of underwater images. Reduce scattering is a major challenge in underwater image processing hence developing reliable methods for evaluating and quantifying image quality, sensor design and designing effective imaging sensors for underwater environments are different problems in underwater image processing.

## 2. Background

Integrating deep learning techniques such as object detection, segmentation, and colorization, improves image quality, restores colours, and enhances visibility in underwater environments more effectively than using individual models in isolation.

### 2.1 Detectron

The Detectron technology was developed by Facebook AI Research and consists of other version, namely, Detectron2. Detectron2 is based on deep learning and the PyTorch framework. This modular object detection framework has a most accurate mask and object detection algorithms. For object Detection, Detectron2 uses Mask R-CNN and a different set of backbone network and powerful analysis networks like ResNet as shown in figure 2.

- i. Object Detection: Detectron2 uses state-of-the-art algorithms for object detection, for example faster R-CNN, mask R-CNN, RetinaNet, and others. It also supports various backbone network architectures, such as ResNet and ResNeXt that improve the object detection model accuracy, as in figure 2.

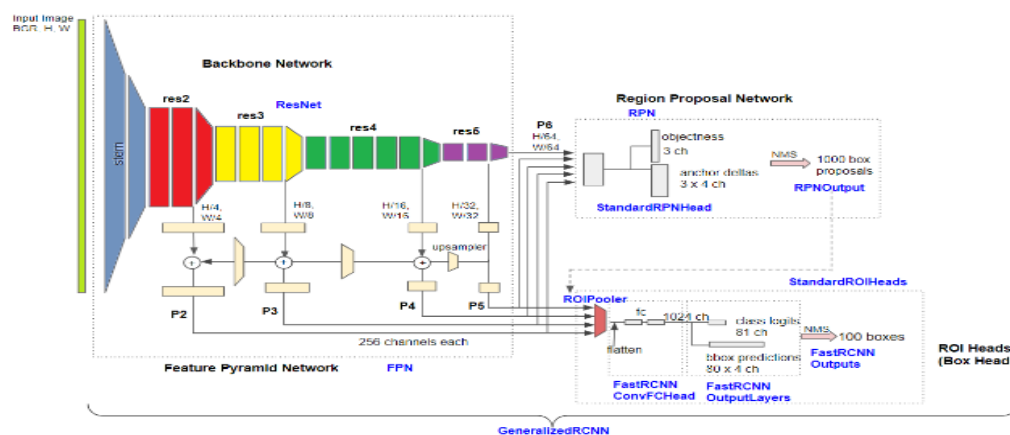
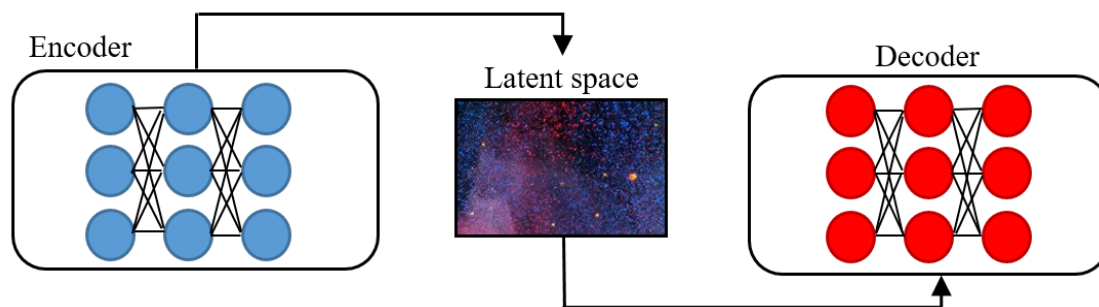

Fig. 2. Architecture of Detectron2

- ii. The platform allows for the training of new models from scratch, enabling users to customize configurations and fine-tune hyper parameters based on specific requirements.
- iii. Instance Segmentation: Detectron2 has features like panoptic segmentation, Cascade R-CNN, rotated bounding boxes and MViTv2 and enhancing the background segmentation accuracy and detail.
- iv. Feature Extraction: This model also supports feature extraction, enabling the extraction of meaningful features from images or videos for various downstream tasks.

### 2.2 Autoencoders

Autoencoders use unsupervised learning to reconstruct the input data. Autoencoder consists of two main components; an encoder and a decoder as depicted in figure 3. The encoder extracts the image features and represents it as a latent space, then the compressed representation is decoded to restore the original image.



**Fig. 3.** A representation for a simple Autoencoder architecture

This allows the Autoencoders to be compatible for feature extraction and image reconstruction. Autoencoders are trained to reconstruct the input data without labels. The model captures the most salient features of the input by minimizing reconstruction errors. They are designed to learn a compressed representation of the input data in the hidden layer.

Autoencoder captures features of the image and enables the model to extract meaningful information for tasks like classification or clustering. One of the primary applications of Autoencoder is image reconstruction. Autoencoders can capture the structure and patterns in the image hence, they are useful for tasks like denoising images, reconstructing colours and generating new synthesized images.

### 2.3 Applications in Image Restoration

For the general users that are not have technical experience proposed model has intended to add more features that are user-friendly applications such as:

- i. Underwater VR Experience: This app targets general audience and virtual reality enthusiasts. It provides a virtual reality experience of underwater environments. Users can explore the marine life, and learn about underwater ecosystems in an educational way. Hatsushika *et al.*, [10] developed an innovative, versatile underwater virtual reality system for scuba training, by using an underwater wired head-mounted display (UWHMD). This app provides accessibility to the swimming pools or shallow water.
- ii. Underwater Species Identification App: this application is very useful to users like Marine biologists and hobbyist divers use image recognition to identify underwater species based on photographs. They can snap pictures of marine life, and the app provides information about the species, contributing to citizen science efforts and educational purposes. Shaobo *et al.*, [11] developed a smart phone app to detect maritime resources like fishes and to help in finding their locations easily.
- iii. Underwater Eco-Tracker: Marine conservationists and citizen scientists need to report and track observations of marine life, pollution, or other ecological changes. The data collected can contribute to scientific research and conservation efforts, fostering community engagement. Poor light in underwater environment leads to low quality imaging makes it hard to identify objects. Some methods, such as Li *et al.*, [12] support deformation suppression to enhance objects that are captured in low resolution for tracking purposes.

There are many underwater image restoration techniques to improve underwater images. For instance Red Channel technique used for colour restoration, CIE Lab (Commission Internationale de l'Eclairage) based colour equalization model [13], paired dataset free Autoencoder [14], low loss convolutional Autoencoder[15], and U-Net model with denoising Autoencoder [16].

Various applications are developed for different purposes, such as the Underwater VR Experience, Underwater Species detection App, and Underwater Eco Tracker. These applications have immersive experiences, species identification through image recognition, and eco-tracking capabilities to support marine conservation efforts.

## 2.4 Traditional Image Enhancement Techniques

Improving images quality helps in applying basic tasks that are needed for various applications like traditional image enhancement techniques. These techniques often involve adjusting contrast, brightness, and sharpness to enhance details and overall image appearance.

### 2.4.1 Histogram Equalization (HE)

Various extensions to Histogram Equalization (HE) method are discussed in [17] as shown in figure 4, classified into four groups that are Global Histogram Equalization (GHE), Mean Brightness Preserving Histogram– Equalization (MBPHE), Bin Modified Histogram Equalization (BMHE), and Local Histogram Equalization (LHE). Global Histogram equalization aims to remap the grayscale image. Based on its cumulative density function, it redistributes the values of the pixels. This method relies on all the information available in the intensity values of an image, therefore it is a suitable candidate for global enhancement.

The primary goal of GHE is to make the intensity of an image proportional throughout the whole range of grey levels, so it is a good image enhancement technique to enhance the low contrast object as it maximizes the entropy of the image. As a result, the image's intensity levels will be spread out so that the plot of resultant image histogram over available intensity levels becomes flatter, which eventually stretches the plot horizontally. The GHE algorithm is adopted, first, by building a Compression Distribution Function based on the image's normalized histogram or Probability Density Function; there is a transformation function termed. This transformation function is then used to map the fed image to the dynamic range. Mean Brightness Preserving Histogram Equalization is used in devices, such as surveillance cameras and televisions, to counter each of these problems.

Finally, the mean brightness of a transformed image is to be equal to the mean brightness of the input image. Mean brightness preserving histogram equalization splits the image recursively into smaller image patches and processes the histogram of each patch independently.

Bin Modified Histogram Equalization (BMHE) addresses the limitation of GHE by modifying the image histogram before equalization based on a threshold. It adjusts the values in histogram to enhance objects that occupy small portions of an image. Local Histogram Equalization (LHE) is introduced to involve with local brightness features of an input image that GHE cannot handle by defining a local transform function for each pixel based on its surrounding neighbouring pixels to enhance images with illumination problems.

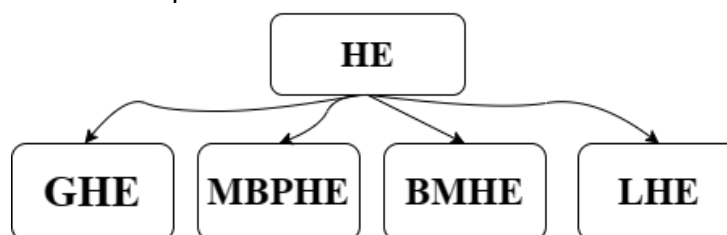

Fig. 4. Block diagram of HE's extensions

#### *2.4.2 Histogram equalization combined with other methods*

Beside Histogram Equalization method, there are another techniques such as an optimized contrast stretching technique using non-linear transformation for image enhancement [18]. Focusing on remote sensing images obtained from satellites. This paper shows the issues of poor contrast images and traditional methods limitations like Histogram Equalization in keeping levels of brightness constant. This method uses Bat algorithm for automated selection of control parameters in the transformation, comparing its performance against other optimization techniques like Ant Colony Optimization and Particle Swarm Optimization. Contrast enhancement that is based on bat algorithm achieved the lowest error and highest peak to signal noise ratio.

#### *2.4.3 Another methods for image enhancement and colour restoration*

Retinex based method involves various algorithms like Multi-Scale Retinex (MSR), Multi-Scale Retinex with modified colour restoration (MSRCR), and Fast Multi-Scale Retinex (FMSR) [19]. Retinex theory was introduced by Edwin Land in 1964, illustrates that the image consists of light and object reflectance. In Single Scale Retinex, a fundamental Retinex-based technique, the illumination is estimated using a linear Low Pass Filter (LPF) on RGB image. The resulting colour image is obtained by subtracting the logarithm of the estimated illumination from the original image.

#### *2.4.4 Capability of the conventional methods in addressing limitations in underwater imagery*

Due to challenges of light attenuation, absorption, and scattering in water these conventional methods are not effective in addressing unique characteristics of underwater images. These factors lead to poor visibility, colour distortion, and reduced contrast in underwater images [20]. Traditional methods like Histogram Equalization (HE) face constraints in handling these issues adequately. Global Histogram Equalization (GHE) enhances contrast by redistributing intensity levels uniformly but may not effectively address localized features.

Mean Brightness Preserving Histogram Equalization (MBPHE) maintains mean brightness but may not fully correct colour casts. Bin Modified Histogram Equalization (BMHE) adjusts histogram values based on a threshold limit, which may not be sufficient for enhancing specific objects. Local Histogram Equalization (LHE) adapts to local brightness features but may struggle with overall image enhancement.

The limitations of Retinex algorithms include a lack of full consideration for the local characteristics of images. While Retinex theory, based on colour constancy, aims to obtain the true picture of a scene by eliminating the influence of the irradiation component on object colour, it may not fully account for the specific localized features present in underwater images. This limitation can impact the effectiveness of Retinex-based methods in addressing challenges for example colour distortion, underexposure, blurring, and other unique characteristics of underwater imagery.

### **3. Literature Review**

Underwater image enhancement methods improve colour, clarity, and contrast, while user-friendly applications offer immersive VR, species identification, and eco-tracking experiences. An underwater sonar visual tracker (USVT) is proposed for stable tracking due to low quality sonar images. Zhang *et al.*, [21] proposed a model that inspired by the Retinex framework, to solve challenges that are caused from underwater particles and light absorption.

LAB-MSR modifies the original Retinex algorithm, utilizing bilateral and trilateral filters in the CIELAB colour space. Tailored to each channel's characteristics, this approach effectively addresses challenges such as blurriness and low contrast. Through experiments with real-world data across varying turbidities, this paper shows LAB-MSR's performance in enhancing underwater image visibility. Galdran *et al.*, [22] proposed an application of a Red Channel technique involves restoring colours linked to shorter wavelengths, a common practice for enhancing underwater images and effectively recovering lost contrast. Lan *et al.*, [23] introduced an approach to enhance hazy images by removing noise from low quality images, this technique is applicable to natural images and not intended for use with aquatic environments.

Codruta *et al.*, [24] introduced a fusion-based strategy that incorporates colour transfer while locally adjusting colour correction based on estimated light attenuation from the red channel then, by applying the Dark Channel Prior (DCP) and a modified Koschmieder light transmission model to restore the colour-compensated image, similar to outdoor dehazing. Kohei *et al.*, [25] introduced exposure bracketing imaging, by rapidly capturing photos in different poses. The long capture image is used for obtaining red channel data, the green and blue channels are selected for their low attenuation.

The comprehensive image is generated from the fusion of its colouring planes. This synthesized image facilitates the precise grey information extraction hence, enabling colour reconstruction using linear regression. Zhang *et al.*, [26] introduces a novel algorithm comprising two components colour correction and illumination adjustment. The colour cast is addressed using an efficient colour enhancement method, followed by illumination adjustment based on the Retinex model. Khan *et al.*, [27] focuses on estimating subsea pipeline corrosion using colour information from degraded images. It increases the image sharpness and pixels intensities to improve image quality.

Nihalaani *et al.*, [28] presents colorization Autoencoder algorithm to restore grayscale images using convolutional neural network. Some of the output images are blurry, but it solves most of colour colorization process challenges.

## 4. Methodology

### 4.1 Proposed Model

This paper proposes a Detectron-Autoencoder hybrid model aimed at enhancing underwater image colour restoration. It processes images with various lighting conditions, such as those taken in bright sunlight and those captured in low-light or shadowed areas. The model performs tasks like feature extraction, focusing on distinguishing between known and unknown species in underwater images, and object segmentation. This segmentation aims to understand the content of the images by dividing them into meaningful segments, which in turn aids in colour restoration and classification. As in figure 5 two deep learning models were combined together. Detectron2 for segmentation has a backbone network (such as ResNet) for feature extraction, a region proposal network (RPN) for generating potential object proposals, a region of interest (ROI) pooling layer for extracting features from proposal regions, a set of task-specific heads for predicting object attributes, and a loss function for training the model.

The colorization Autoencoder has an Encoder that transforms input data into a lower-dimensional representation, and a Decoder that reconstructs colorized images from the Encoder's compact representation.

First, the input RGB image (256\*256\*3) must be in Common Object in Context (COCO) format to be used with Detectron; hence the Roboflow is used to convert the input. After that the obtained output of the Detectron is the image of the segmented object. Second, the output object is fed into

Colorization Autoencoder to restore and fix object’s colours. By duplicating the low quality input image, the output of the Autoencoder is merged with the copy of the origin image to get the whole restored image. The output image can be fed again to the model to make further processing on other objects in the image.

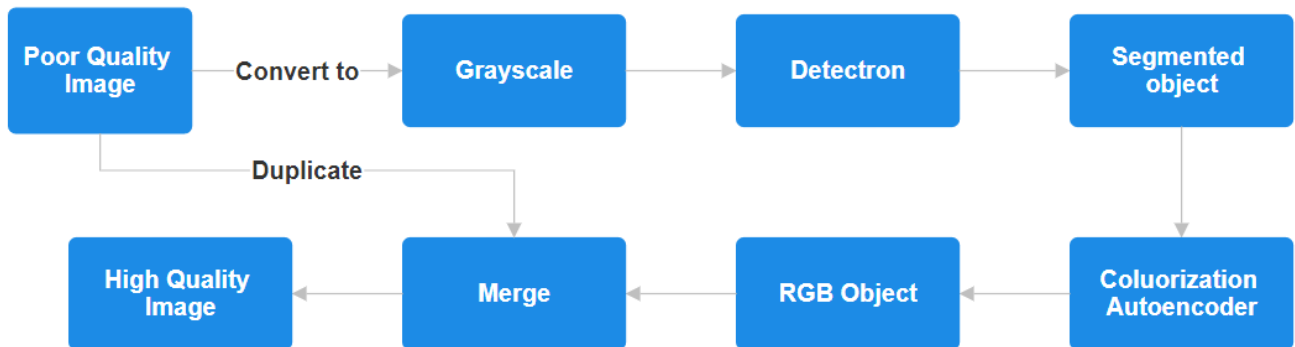

**Fig. 5.** A block diagram on how Autoencoder and Detectron can be combined to reconstruct underwater image

## 4.2 Experimental Setup

All features of the used dataset and training details of the proposed method are discussed in this subsection.

### 4.2.1 Data

The proposed method uses Semantic Segmentation of Underwater Imagery (SUIM) dataset. The main idea behind using this data is to segment underwater images to extract objects for instance fish (vertebrates), reefs (invertebrates), aquatic plants, wrecks/ruins, human divers, robots, and sea-floor. Underwater objects have multiple varieties that are divided into 8 categories. Table 1 presents the categories and their symbols mentioned in SUIM dataset.

**Table 1**

Category and symbol

Category	Symbol
Background(waterbody)	BW
Human divers	HD
Aquatic plants and sea-grass	PF
Wrecks and ruins	WR
Robots (AUVs/ROVs/instruments)	RO
Reefs and invertebrates	RI
Fish and vertebrates	VF
Sea-floor and rocks	SR

As discussed in Detectron background section, proposed model uses panoptic segmentation to work on BW category and instance segmentation to work on HD, PF, RO and VF categories. Number of provided input images is 887, 70% of them are specified for training, 10% validation and 20% for testing. Training data were shuffled randomly with 400 epochs considered.

#### 4.2.2 Training

In Detectron, training a Mask R-CNN model using the Detectron2 library. We start by setting up a configuration file (.cfg) for the model. The configuration file contains many details including the output directory path, training dataset information, pre-trained weights, base learning rate and maximum number of iterations. Detectron2 model basically is a Generalized Region Based Convolutional Neural Network RCNN consists of Feature Pyramid Network FPN as backbone, Region Proposal Network RPN and Region of interests ROI Heads to process feature maps of selected regions from the image. The FPN consists of 8 convolution layers followed by a max pool layer and 5 Resnets. Each Resnet has from 3 to 6 bottleneck blocks, each block has 3 convolutional layers see figure 6.

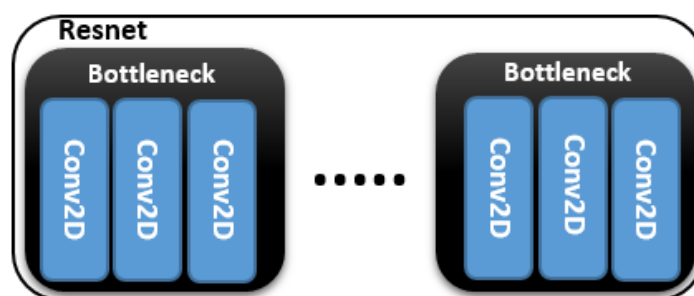

Fig. 6. A visualization for Resnet components in our Detectron2 model

The Autoencoder consists of 1 input layer, 8 convolutional layers for encoding and 5 convolutional layers for decoding. Each encoding layer uses the Rectified Linear Unit (ReLU) activation function and strides of two. Input layer has 64 filters. The encoder has 128, 128, 256, 256, 512, 512 filters for each encoding layer respectively. The last convolutional layer in the encoder has 256 filters. The decoder consists of five Conv2D layers followed by upsampling layers (UpSampling2D) to restore the image resolution. The decoder has 128, 64, 32, 16, 2 filters for each decoding layer respectively. The last Conv2D layer in the decoder uses the hyperbolic tangent (tanh) activation function to output the colorized A and B channels. The Colorization Autoencoder is compiled using Adam optimizer with batch size = 20, mean squared error (mse) loss, and accuracy. The integration process between the object detection features extracted by the Detectron model and the image reconstruction abilities of the Autoencoder to enhance the quality and visibility of underwater images involves a collaborative approach that leverages the strengths of both components. Firstly, the Detectron model is utilized to identify objects and features in the underwater scene, providing valuable information about the elements present.

Autoencoders feeding data represented by these detected features that reconstruct and colorize the image. After the Detectron extracts object features, the Autoencoder processes this information to refine the image, enhance colours, and reconstruct a clearer representation of the underwater scene. The image is improved by increasing the functionalities of the Autoencoders to enhance image quality and the Detectron model to identify objects accurately the integration process aims to produce visually improved underwater images with enhanced clarity, sharpness, and overall quality.

#### 4.3 Challenges in Segmenting Different Classes

Many challenges are addressed while training the data on our model. Each class has its challenges detailed as below:

- i. Fish images: objects of fishes are interfered with background and the colour intensities are degraded, so we used diverse images and motion blur to increase accuracy.
- ii. Reefs: while the shape is blended with background, it's hard to separate it from the background, so we have trained the model on multi scaled and high resolution images.
- iii. Plants: they are very hard to be detected by the model as they, in the deep water, get merged with other objects so we have done multiple processing with various augmentations under difference circumstances.
- iv. Wrecks: deep water has bad environment, hence bad visibility. We have employed much more convolution layers to segment the shape accurately.
- v. Human divers: human makes many interactions with other shapes these interactions blur the object and the human diver. To solve this we have considered many diver appearances in our dataset
- vi. Robots: machines are designed to get in the deep sea but while imaging its complex to get the coordinates of the object accurately, so we have trained our model on many underwater robots designs.
- vii. Sea floor: deep sea has many changes affect the quality, we have trained the model on various sea-floor types.

## **5. Results**

In this section, details of the results that show proposed model efficiency is discussed. We propose underwater image colour restoration using Autoencoder Detectron hybrid model. By incorporating Deep learning, we can effectively leverage information from multiple underwater images categories simultaneously, unlike conventional models that learn from each category only. Our investigation demonstrates that the adoption of an Autoencoder Detectron architecture yields more accurate results compared to traditional approaches as its Peak to Signal Noise Ratio 24.1 and Structural Similarity Index 94 %.

To conduct our experiments, we randomized the dataset into one training folder, one corresponding test folder and one validation folder. Training folder contains 80% of the entire dataset, test folder contains 10% and the validation folder encompassed the remaining 10%. Consequently, the final dataset comprised training folder (train), one test folder (test), and finally one validation folder (val).

## **6. Discussion of Loss Curves**

The purposed model has achieved good loss scores in bounding box 0.841, with segmentation loss 1.29 and classification loss 1.7247 in training, while it has achieved 1.40, 3.95, and 3.52 for bounding box, segmentation and classification respectively see figure 7.

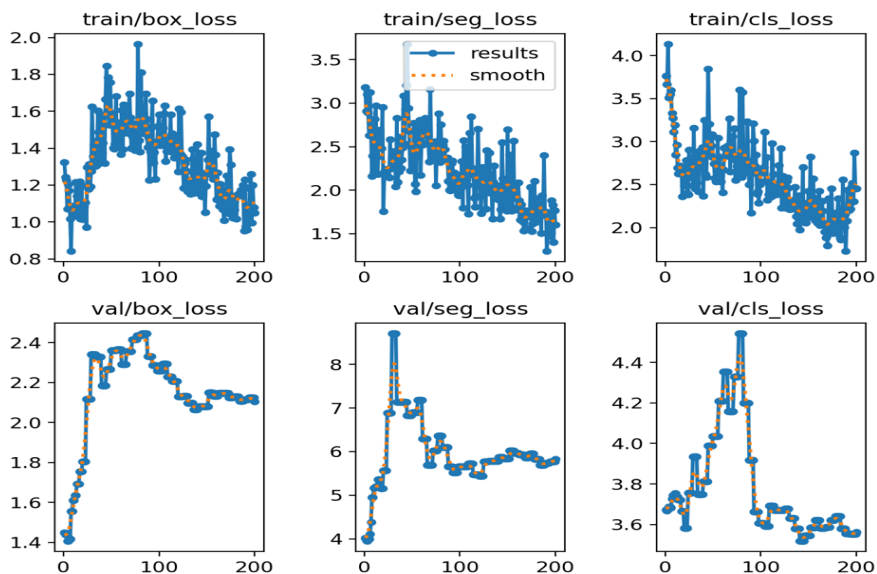

Fig. 7. Loss rate curves

### 7. A Comparison between the Proposed Model and YOLOv8 with Same Dataset

In Table 2 we illustrate how the image is being segmented so the object can be obtained accurately with its correct boundaries. Here are some samples of our results. Table 1 demonstrates that our Detectron2 merged with Autoencoder that is trained with different parameters performs better than YOLO (You Only Look Once) only. However, in classification YOLO outperforms Detectron as we processed grey channel images not RGB.

Table 2

Visualizing results of losses for each task

Parameters	YOLOv8 only [28]	Proposed Model
Classification	<b>0.87</b>	1.7
Segmentation	1.5	<b>1.3</b>
Bound Box	1.017	<b>0.84</b>

In the above representation figure 8 we have used mix of our data and explicit images from previous work. We add more 10k images and divided them into 3 batches during training so the model can give better results.

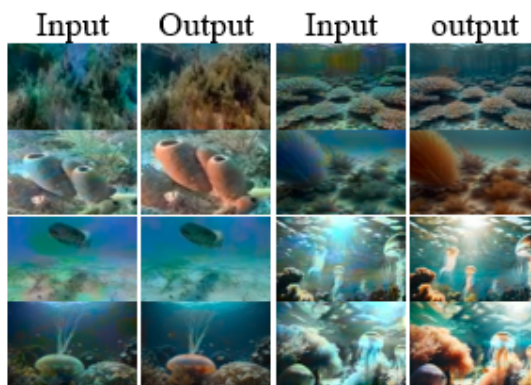

Fig. 8. Presenting samples of reconstructed underwater images

## 8. Conclusion

This study has proved that image colorization plays an important role in enhancing color restoration for underwater images. Proposed paper has proved the effectiveness of image colorization by utilizing Detectron2 for image segmentation. Proposed architecture employs the model to perform segmentation efficiently. The experimental evaluations conducted with underwater categories datasets have validated the model's abilities to enhance underwater image colorization process. The results obtained from the experiments encourage further research in image colorization.

In addition, when Detectron combined with the proposed architecture gives better results than using YOLOv8. In the future work, segmentation process aimed to be enhanced by merging other segmentation models with the proposed model to give multiple form of the segmented object. The idea of the future work is to handle underwater images from different categories.

## Acknowledgement

This research was not funded by any grant.

## References

- [1] Schettini, Raimondo, and Silvia Corchs. "Underwater image processing: state of the art of restoration and image enhancement methods." *EURASIP journal on advances in signal processing* 2010, no. 1 (2010): 746052. <https://doi.org/10.1155/2010/746052>
- [2] Akkaynak, Derya, and Tali Treibitz. "A revised underwater image formation model." In *Proceedings of the IEEE conference on computer vision and pattern recognition*, pp. 6723-6732. 2018. <https://doi.org/10.1109/CVPR.2018.00703>
- [3] Angara, Bhogeswara Rao, Palanisamy Shanmugam, and Harisankar Ramachandran. "Influence of sea surface waves and bubbles on the performance of underwater-to-air optical wireless communication system." *Optics & Laser Technology* 174 (2024): 110652. <https://doi.org/10.1016/j.optlastec.2024.110652>
- [4] Doron, Maéva, Marcel Babin, Antoine Mangin, and Odile Hembise. "Estimation of light penetration, and horizontal and vertical visibility in oceanic and coastal waters from surface reflectance." *Journal of Geophysical Research: Oceans* 112, no. C6 (2007). <https://doi.org/10.1029/2006JC004007>
- [5] Korotkova, Olga. "Light propagation in a turbulent ocean." In *Progress in Optics*, vol. 64, pp. 1-43. Elsevier, 2019. <https://doi.org/10.1016/bs.po.2018.09.001>
- [6] Jian, Muwei, Xiangyu Liu, Hanjiang Luo, Xiangwei Lu, Hui Yu, and Junyu Dong. "Underwater image processing and analysis: A review." *Signal Processing: Image Communication* 91 (2021): 116088. <https://doi.org/10.1016/j.image.2020.116088>
- [7] Abang Shakawi, Abang Mohammad Hudzaifah, and Ani Shabri. 2024. "Adaptability of Statistical and Deep Learning Models to Volatile Market Conditions in Bursa Malaysia Stock Index Forecasting". *Semarak International Journal of Machine Learning* 4 (1):1-13. <https://doi.org/10.37934/sijml.4.1.113>.
- [8] Nazim, Nor'Awatif Amri Muhammad, Normi Abdul Hadi, Mohd Rijal Ilias, Dian Kurniasari, and Suhaila Abd Halim. "Application of Different Distance Metrics on K-Means Clustering Algorithm for Retinal Vessel Images." *Semarak International Journal of Machine Learning* 4, no. 1 (2024): 14-26. <https://doi.org/10.37934/sijml.4.1.1426>.
- [9] Azlan, Nur Hanani Ahmad, Nik Mohd Ridzuan Shaharuddin, and Arifah Ali. "Impact of Wave Directions on Connector Forces in Hexagonal Modular Floating Structure Networks." *Journal of Ship and Marine Structures* 7, no. 1 (2024): 1-11. <https://doi.org/10.37934/sijaff.1.1.1018>
- [10] Hatsushika, Denik, Kazuma Nagata, and Yuki Hashimoto. "Underwater vr experience system for scuba training using underwater wired hmd." In *OCEANS 2018 MTS/IEEE Charleston*, pp. 1-7. IEEE, 2018. <https://doi.org/10.1109/OCEANS.2018.8604592>
- [11] Shaobo, L. I., Y. A. N. G. Ling, Y. U. Huihui, and C. H. E. N. Yingyi. "Underwater Fish Species Identification Model and Real-Time Identification System." *Smart Agriculture* 4, no. 1 (2022): 130. [10.12133/j.smartag.SA202202006](https://doi.org/10.12133/j.smartag.SA202202006)
- [12] Li, Wenge, Meiqin Liu, Senlin Zhang, Ronghao Zheng, and Jian Lan. "Underwater sonar visual tracking with obstacle solving method." In *2020 39th Chinese Control Conference (CCC)*, pp. 3044-3049. IEEE, 2020. <https://doi.org/10.23919/CCC50068.2020.9189400>

- [13] Akhtarshenas, Azim, and Ramin Toosi. "An open-set framework for underwater image classification using autoencoders." *SN Applied Sciences* 4, no. 8 (2022): 229. <https://doi.org/10.1007/s42452-022-05105-w>
- [14] Mello, Claudio D., Bryan U. Moreira, Paulo LJ Drews, and Silvia C. Botelho. "Alternative underwater image restoration based on unsupervised learning and autoencoder with degradation block." In *2020 Latin American Robotics Symposium (LARS), 2020 Brazilian Symposium on Robotics (SBR) and 2020 Workshop on Robotics in Education (WRE)*, pp. 1-6. IEEE, 2020. <https://doi.org/10.1109/LARS/SBR/WRE51543.2020.9307136>
- [15] Yasukawa, Shinsuke, Sreeraman Srinivasa Raghura, Yuya Nishida, and Kazuo Ishii. "Underwater image reconstruction using convolutional auto-encoder." In *Proc. Int. Conf. Artif. Life Robot.*, pp. 262-265. 2021. <https://doi.org/10.5954/ICAROB.2021.OS23-4>
- [16] Hashisho, Yousif, Mohamad Albadawi, Tom Krause, and Uwe Freiherr von Lukas. "Underwater color restoration using u-net denoising autoencoder." In *2019 11th International Symposium on Image and Signal Processing and Analysis (ISPA)*, pp. 117-122. IEEE, 2019. <https://doi.org/10.1109/ISPA.2019.8868679>
- [17] Kong, Nicholas Sia Pik, Haidi Ibrahim, and Seng Chun Hoo. "A literature review on histogram equalization and its variations for digital image enhancement." *International Journal of Innovation, Management and Technology* 4, no. 4 (2013): 386. <https://doi.org/10.7763/IJIMT.2013.V4.426>
- [18] Asokan, Anju, Daniela E. Popescu, Jude Anitha, and D. Jude Hemanth. "Bat algorithm based non-linear contrast stretching for satellite image enhancement." *geosciences* 10, no. 2 (2020): 78. <https://doi.org/10.3390/geosciences10020078>
- [19] Sankpal, S. S., and Shraddha S. Deshpande. "A review on image enhancement and color correction techniques for underwater images." *Advances in Computational Sciences and Technology* 9, no. 1 (2016): 11-23. <https://doi.org/10.1155/2016/5718297>
- [20] Deng, Xiwen, Tao Liu, Shuangyan He, Xinyao Xiao, Peiliang Li, and Yanzhen Gu. "An underwater image enhancement model for domain adaptation." *Frontiers in Marine Science* 10 (2023): 1138013. <https://doi.org/10.3389/fmars.2023.1138013>
- [21] Zhang, Shu, Ting Wang, Junyu Dong, and Hui Yu. "Underwater image enhancement via extended multi-scale Retinex." *Neurocomputing* 245 (2017): 1-9. <https://doi.org/10.1016/j.neucom.2017.03.029>
- [22] Galdran, Adrian, David Pardo, Artzai Picón, and Aitor Alvarez-Gila. "Automatic red-channel underwater image restoration." *Journal of Visual Communication and Image Representation* 26 (2015): 132-145. <https://doi.org/10.1016/j.jvcir.2014.11.006>
- [23] Lan, Xia, Liangpei Zhang, Huanfeng Shen, Qiangqiang Yuan, and Huifang Li. "Single image haze removal considering sensor blur and noise." *EURASIP journal on advances in signal processing* 2013, no. 1 (2013): 86. <https://doi.org/10.1186/1687-6180-2013-86>
- [24] Ancuti, Codruta O., Cosmin Ancuti, Christophe De Vleeschouwer, and Rafael Garcia. "Locally adaptive color correction for underwater image dehazing and matching." In *Proceedings of the IEEE conference on computer vision and pattern recognition workshops*, pp. 1-9. 2017. <https://doi.org/10.1109/CVPRW.2017.136>
- [25] Nomura, Kohei, Daisuke Sugimura, and Takayuki Hamamoto. "Underwater image color correction using exposure-bracketing imaging." *IEEE Signal Processing Letters* 25, no. 6 (2018): 893-897. <https://doi.org/10.1109/LSP.2018.2831630>
- [26] Zhang, Wenhao, Ge Li, and Zhenqiang Ying. "A new underwater image enhancing method via color correction and illumination adjustment." In *2017 IEEE Visual Communications and Image Processing (VCIP)*, pp. 1-4. IEEE, 2017. <https://doi.org/10.1109/VCIP.2017.8305027>
- [27] Khan, Amjad, Syed Saad Azhar Ali, Atif Anwer, Syed Hasan Adil, and Fabrice Mériaudeau. "Subsea pipeline corrosion estimation by restoring and enhancing degraded underwater images." *IEEE Access* 6 (2018): 40585-40601. <https://doi.org/10.1109/ACCESS.2018.2855725>
- [28] Nihalaani, Rachael, Simran Mansharamani, and Juhi Janjua. "Image Colorization Using Autoencoders." <https://doi.org/10.22214/ijraset.2021.38218>
- [29] Jia, Rong, Bin Lv, Jie Chen, Hailin Liu, Lin Cao, and Min Liu. "Underwater object detection in marine ranching based on improved YOLOv8." *Journal of Marine Science and Engineering* 12, no. 1 (2023): 55. <https://doi.org/10.3390/jmse12010055>